

## Chapter 1

### Lecture 2

#### Introduction – 2

#### Topics

##### **1.4 Equilibrium of airplane**

##### **1.5 Number of equations of motion for airplane in flight**

1.5.1 Degrees of freedom

1.5.2 Degrees of freedom for a rigid airplane

##### **1.6 Subdivisions of flight dynamics**

1.6.1 Performance analysis

1.6.2 Stability and control analysis

##### **1.7 Additional definitions**

1.7.1 Attitude of the airplane

1.7.2 Flight path

1.7.3 Angle of attack and side slip

### 1.4 Equilibrium of airplane

The above three types of forces (aerodynamic, propulsive and gravitational) and the moments due to them govern the motion of an airplane in flight.

If the sums of all these forces and moments are zero, then the airplane is said to be in equilibrium and will move along a straight line with constant velocity (see Newton's first law). If any of the forces is unbalanced, then the airplane will have a linear acceleration in the direction of the unbalanced force. If any of the moments is unbalanced, then the airplane will have an angular acceleration about the axis of the unbalanced moment.

The relationship between the unbalanced forces and the linear accelerations and those between unbalanced moments and angular accelerations are provided by Newton's second law of motion. These relationships are called equations of motion.

### 1.5 Number of equations of motion for an airplane in flight

To derive the equations of motion, the acceleration of a particle on the body needs to be known. The acceleration is the rate of change of velocity and the velocity is the rate of change of position vector with respect to the chosen frame of reference.

#### 1.5.1 Degrees of freedom

The minimum number of coordinates required to prescribe the motion is called the number of degrees of freedom. The number of equations governing the motion equals the degrees of freedom. As an example, it may be recalled that the motion of a particle moving in a plane is prescribed by the x- and y-coordinates of the particle at various instants of time and this motion is described by two equations.

Similarly, the position of any point on a rigid pendulum is describe by just one coordinate namely the angular position ( $\theta$ ) of the pendulum (Fig.1.8). In this case only one equation is sufficient to describe the motion. In yet another

Flight dynamics-I  
Chapter-1

example, if a particle is constrained to move on a sphere, then its position is completely prescribed by the longitude and the latitude. Hence, this motion has only two degrees of freedom.

From the discussion in this subsection it is clear that the coordinates needed to prescribe the motion could be lengths and/or angles.

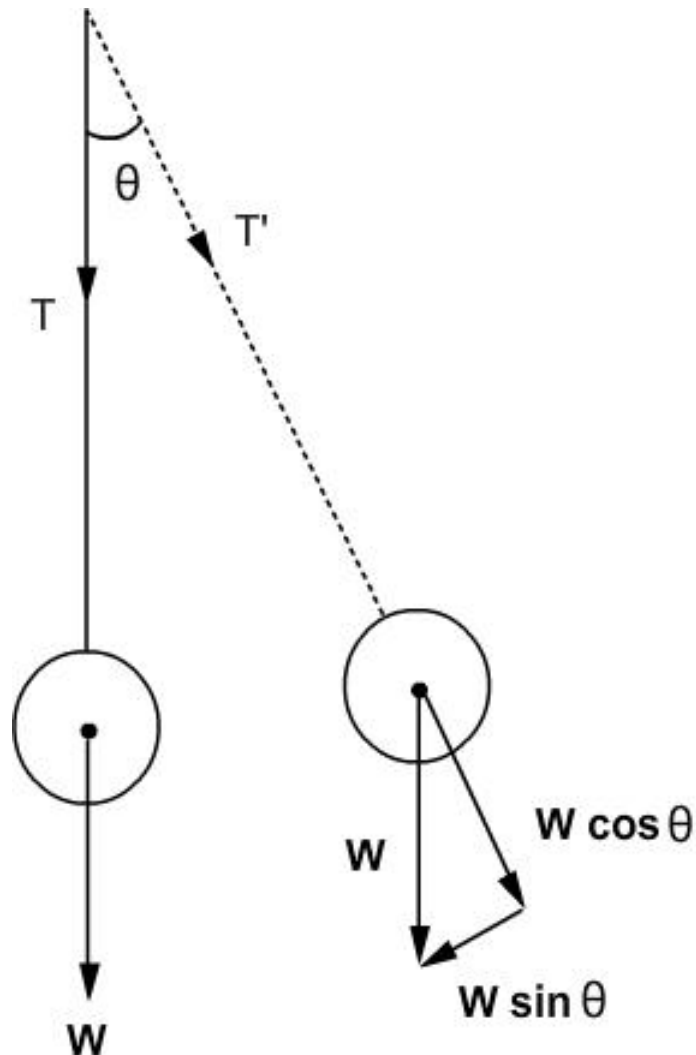

Note : The bobs in the figure are circular in shape. Please adjust the resolution of your monitor so that they look circular.

Fig.1.8 Motion of a single degree of freedom system

### 1.5.2 Degrees of freedom for a rigid airplane

To describe its motion, the airplane is treated as a rigid body. It may be recalled that in a rigid body the distance between any two points is fixed. Thus the distance  $r$  in Fig. 1.9 does not change during the motion. To decide the

Flight dynamics-I  
Chapter-1

minimum number of coordinates needed to prescribe the position of a point on a rigid body which is translating and rotating, one may proceed as follows.

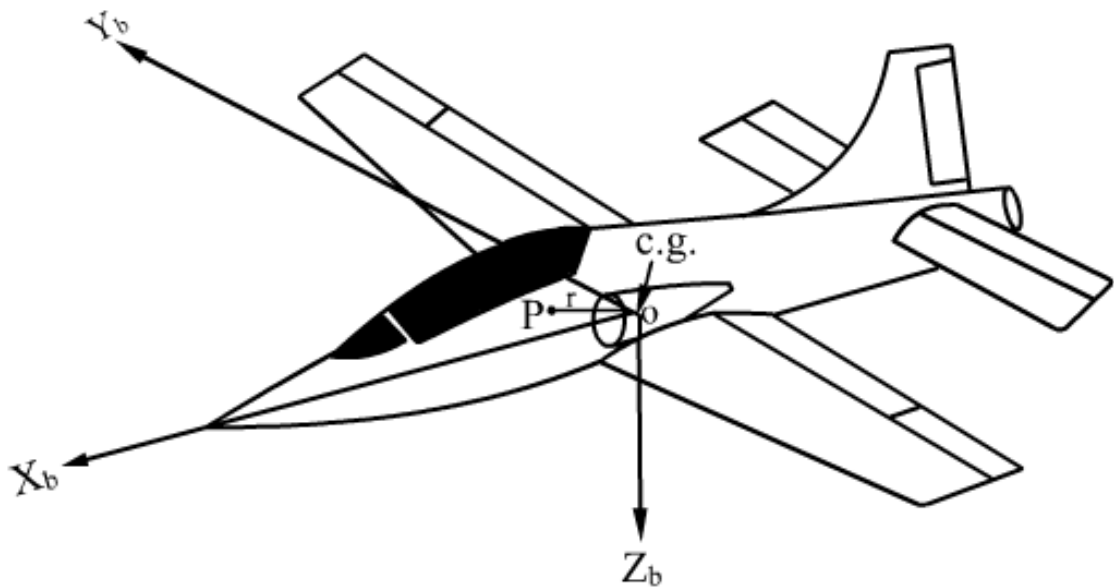

Fig.1.9 Position of a point on a rigid airplane

A rigid body with  $N$  particles may appear to have  $3N$  degrees of freedom, but the constraint of rigidity reduces this number. To arrive at the minimum number of coordinates, let us approach the problem in a different way. Following Ref.1.3, it can be stated that to fix the location of a point on a rigid body one does not need to prescribe its distance from all the points, but only needs to prescribe its distance from three points which do not lie on the same line (points 1, 2 and 3 in Fig.1.10a). Thus, if the positions of these three points are prescribed with respect to a reference frame, then the position of any point on the body is known. This may indicate nine degrees of freedom. This number is reduced to six because the distances  $s_{12}$ ,  $s_{23}$  and  $s_{13}$  in Fig.1.10a are constants.

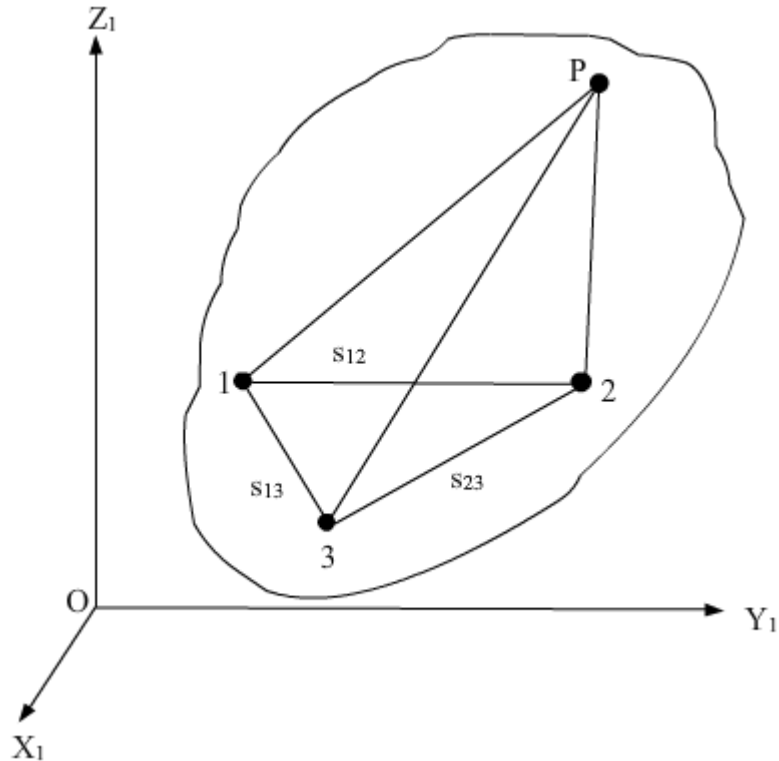

Fig.1.10a Position of a point with respect to three reference points

Another way of looking at the problem is to consider that the three coordinates of point 1 with respect to the reference frame are prescribed. Now the point 2 is constrained, because of rigid body assumption, to move on a sphere centered on point 1 and needs only two coordinates to prescribe its motion. Once the points 1 and 2 are determined, the point 3 is constrained, again due to rigid body assumption, to move on a circle about the axis joining points 1 and 2. Hence, only one independent coordinate is needed to prescribe the position of point 3. Thus, the number of independent coordinates is six ( $3+2+1$ ). Or a rigid airplane has six degrees of freedom.

In dynamics the six degrees of freedom associated with a rigid body, consist of the three coordinates of the origin of the body with respect to the chosen frame of reference and the three angles which describe the angular position of a coordinate system fixed on the body ( $Ox_bY_bZ_b$ ) with respect to the

Flight dynamics-I  
Chapter-1

fixed frame of reference ( $EX_eY_eZ_e$ ) as shown in Fig.1.10b. These angles are known as Eulerian angles. These are discussed in ch.7 of flight dynamics- II. See also Ch.4 of Ref.1.3.

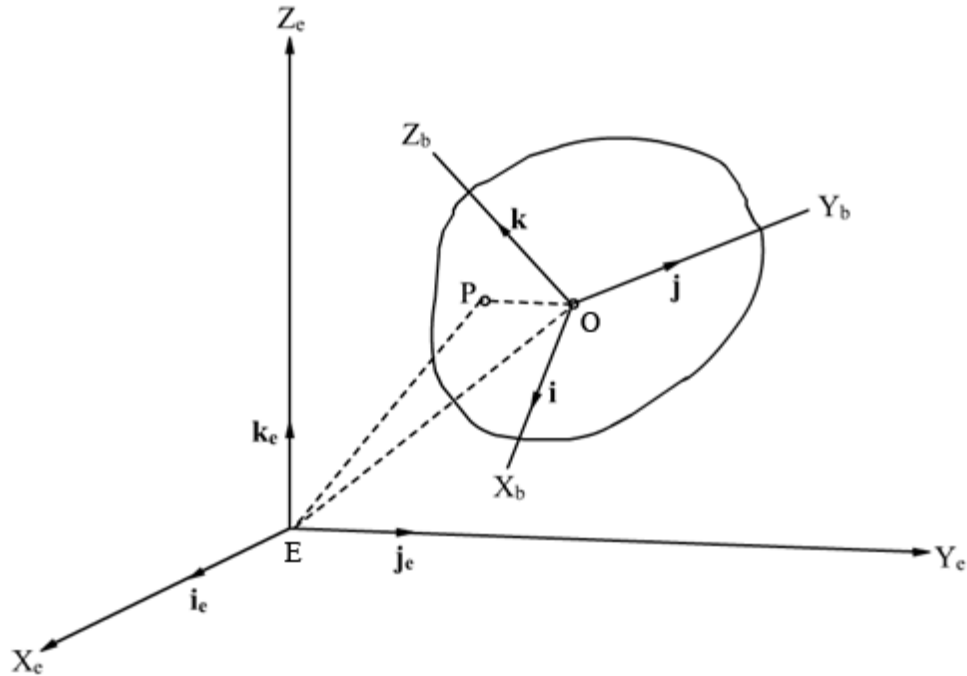

Fig.1.10b Coordinates of a point (P) on a rigid body

**Remarks:**

- i) The derivation of the equations of motions in a general case with six degrees of freedom (see chapter 7 of Flight dynamics-II or Ref.1.4 chapter 10, pt.3 or Ref.1.5, chapter 10) is rather involved and would be out of place here.
- ii) Here, various cases are considered separately and the equations of motion are written down in each case.

**1.6 Subdivisions of flight dynamics**

The subject of flight dynamics is generally divided into two main branches viz.

- (i) Performance analysis and (ii) Stability and control

**1.6.1 Performance Analysis**

In performance analysis, only the equilibrium of forces is generally considered. It is assumed that by proper deflections of the controls, the moments

## Flight dynamics-I

### Chapter-1

can be made zero and that the changes in aerodynamic forces due to deflection of controls are small. The motions considered in performance analysis are steady and accelerations, when involved, do not change rapidly with time.

The following motions are considered in performance analysis

- Unaccelerated flights,
  - Steady level flight
  - Climb, glide and descent
- Accelerated flights,
  - Accelerated level flight and climb
  - Loop, turn, and other motions along curved paths which are called manoeuvres
  - Take-off and landing.

#### 1.6.2 Stability and control analyses

Roughly speaking, the stability analysis is concerned with the motion of the airplane, from the equilibrium position, following a disturbance. Stability analysis tells us whether an airplane, after being disturbed, will return to its original flight path or not.

Control analysis deals with the forces that the deflection of the controls must produce to bring to zero the three moments (rolling, pitching and yawing) and achieve a desired flight condition. It also deals with design of control surfaces and the forces on control wheel/stick /pedals. Stability and control are linked together and are generally studied under a common heading.

Flight dynamics - I deals with performance analysis. By carrying out this analysis one can obtain various performance characteristics such as maximum level speed, minimum level speed, rate of climb, angle of climb, distance covered with a given amount of fuel called 'Range', time elapsed during flight called 'Endurance', minimum radius of turn, maximum rate of turn, take-off distance, landing distance etc. The effect of flight conditions namely the weight, altitude and flight velocity of the airplane can also be examined. This study would also help in solving design problems of deciding the power required, thrust required,

## Flight dynamics-I

### Chapter-1

fuel required etc. for given design specifications like maximum speed, maximum rate of climb, range, endurance etc.

#### Remark:

Alternatively, the performance analysis can be considered as the analysis of the motion of flight vehicle considered as a point mass, moving under the influence of applied forces (aerodynamic, propulsive and gravitational forces). The stability analysis similarly can be considered as motion of a vehicle of finite size, under the influence of applied forces and moments.

### 1.7 Additional definitions

#### 1.7.1 Attitude

As mentioned in section 1.5.2 the instantaneous position of the airplane, with respect to the earth fixed axes system ( $OX_eY_eZ_e$ ), is given by the coordinates of the c.g. at that instant of time. The attitude of the airplane is described by the angular orientation of the  $OX_bY_bZ_b$  system with respect to  $OX_eY_eZ_e$  system or the Euler angles. Reference 1.4, chapter 10 may be referred to for details. Let us consider simpler cases. When an airplane climbs along a straight line its attitude is given by the angle ' $\gamma$ ' between the axis  $OX_b$  and the horizontal (Fig.1.11a). When an airplane executes a turn, the projection of  $OX_b$  axis, in the horizontal plane, makes an angle  $\Psi$  with reference to a fixed horizontal axis (Fig.1.11b). When an airplane is banked the axis  $OY_b$  makes an angle  $\phi$  with respect to the horizontal (Fig.1.11c) and the axis  $OZ_b$  makes an angle  $\phi$  with respect to the vertical.

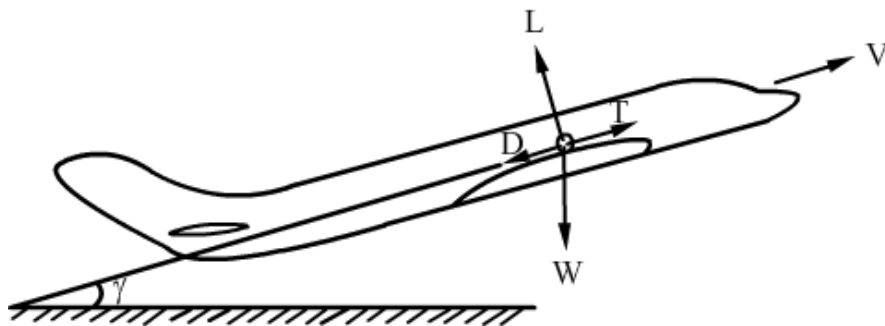
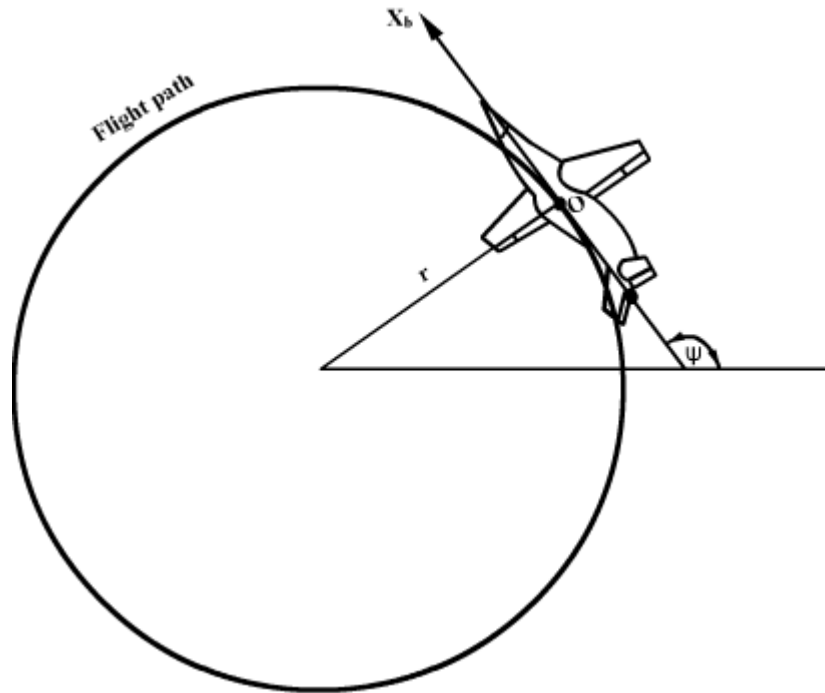

Fig.1.11a Airplane in a climb





Note : The flight path is circular. Please adjust the resolution of your monitor so that the flight path looks circular

Fig.1.11b Airplane in a turn - view from top

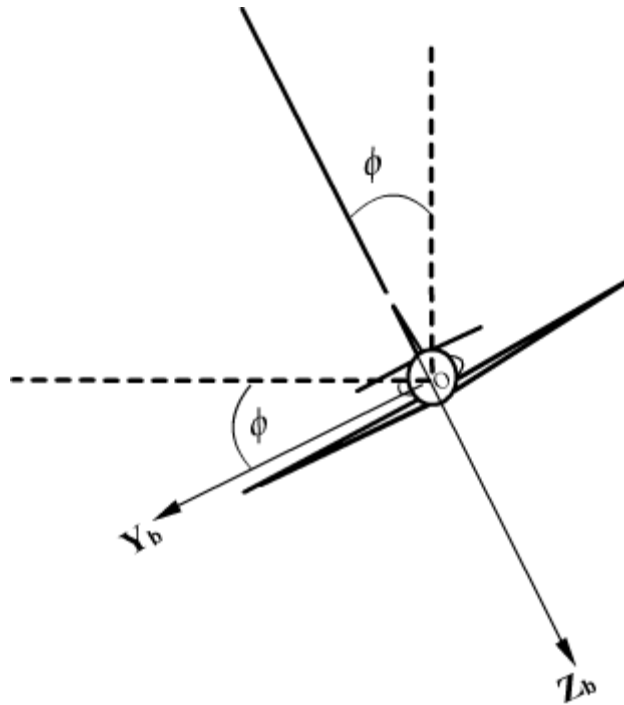

Fig.1.11c Angle of bank ( $\phi$ )

### 1.7.2 Flight path

In the subsequent sections, the flight path, also called the trajectory, means the path or the line along which the c.g. of the airplane moves. The tangent to this curve at a point gives the direction of flight velocity at that point on the flight path. The relative wind is in a direction opposite to that of the flight velocity.

### 1.7.3. Angle of attack and side slip

While discussing the forces acting on an airfoil, the chord of the airfoil is taken as the reference line and the angle between the chord line and the relative wind is the angle of attack ( $\alpha$ ). The aerodynamic forces viz. lift ( $L$ ) and drag ( $D$ ), produced by the airfoil, depend on the angle of attack ( $\alpha$ ) and are respectively perpendicular and parallel to relative wind direction (Fig.1.11 d).

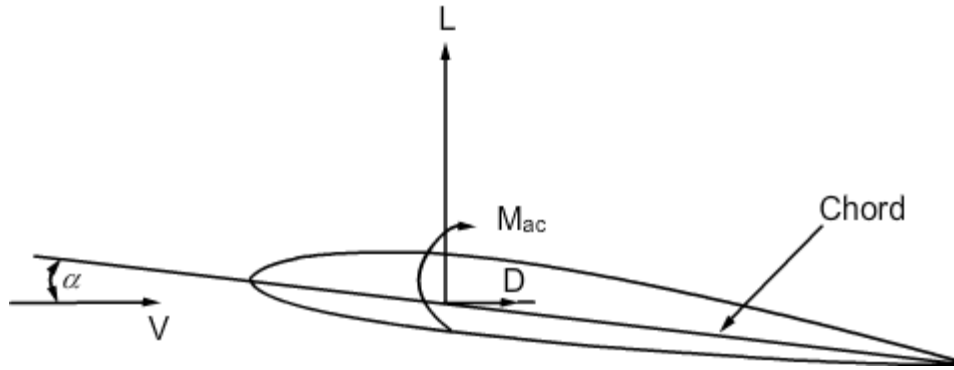

Fig.1.11d Angle of attack and forces on a airfoil

In the case of an airplane the flight path, as mentioned earlier, is the line along which c.g. of the airplane moves. The tangent to the flight path is the direction of flight velocity ( $V$ ). The relative wind is in a direction opposite to the flight velocity. If the flight path is confined to the plane of symmetry, then the angle of attack would be the angle between the relative wind direction and the fuselage reference line (FRL) or  $OX_b$  axis (see Fig.1.11e). However, in a general case the velocity vector ( $V$ ) will have components both along and perpendicular to the plane of symmetry. The component perpendicular to the plane of symmetry is denoted by ' $v$ '. The projection of the velocity vector in the plane of symmetry would have components  $u$  and  $w$  along  $OX_b$  and  $OZ_b$  axes (Fig.1.11f). With this background the angle of sideslip and the angle of attack are defined as follows.

Flight dynamics-I  
Chapter-1

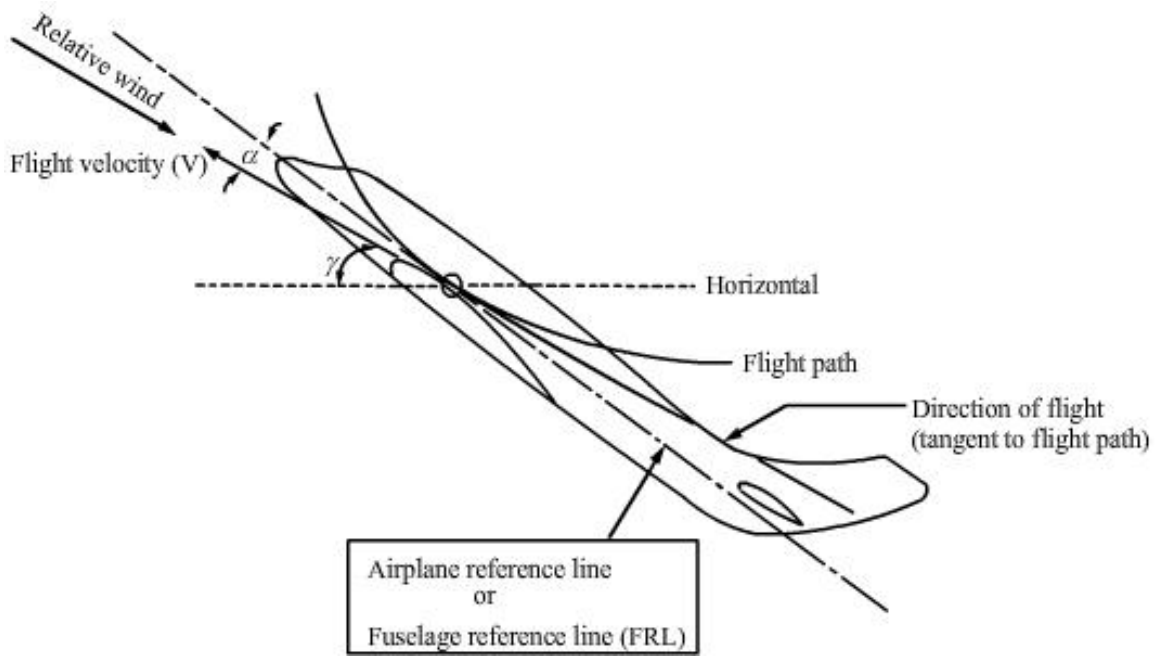
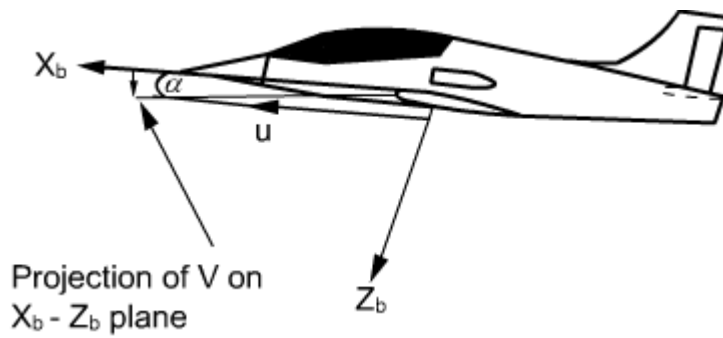

Fig.1.11e Flight path in the plane of symmetry



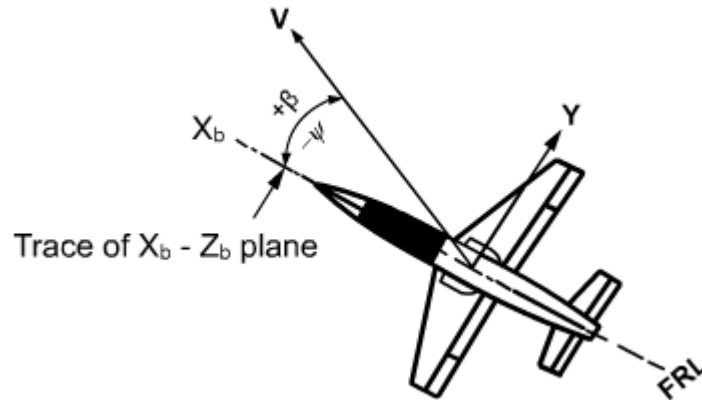

Fig.1.11f Velocity components in a general case and definition of angle of attack and sideslip

The angle of sideslip ( $\beta$ ) is the angle between the velocity vector ( $\mathbf{V}$ ) and the plane of symmetry i.e.

$$\beta = \sin^{-1} (v/ |\mathbf{V}|); \text{ where } |\mathbf{V}| \text{ is the magnitude of } \mathbf{V}.$$

The angle of attack ( $\alpha$ ) is the angle between the projection of velocity vector ( $\mathbf{V}$ ) in the  $X_b - Z_b$  plane and the  $OX_b$  axis or

$$\alpha = \tan^{-1} \frac{w}{u} = \sin^{-1} \frac{w}{\sqrt{|\mathbf{V}|^2 - v^2}} = \sin^{-1} \frac{w}{\sqrt{u^2 + w^2}}$$

**Remarks:**

- i) It is easy to show that, if  $V$  denotes magnitude of velocity ( $\mathbf{V}$ ), then  $u = V \cos \alpha \cos \beta$ ,  $v = V \sin \beta$ ;  $w = V \sin \alpha \cos \beta$ .
- ii) By definition, the drag ( $D$ ) is parallel to the relative wind direction. The lift force lies in the plane of symmetry of the airplane and is perpendicular to the direction of flight velocity.